

HUNTER HVLS FAN DROP TUBES

HUNTER RM SERIES RIGID DOWNROD



DESCRIPTION

Rigid all-in-one, pre-wired downrod with self leveling mount bracket that locks into place.

FEATURES

- Pre-wired with power and safety cable
- No guide wires required
- Integrated motor mounting plate
- Self-levelling mount bracket that is locked into place once set
- Recommended for the Hunter RM series of HVLS fans

DIMENSIONS

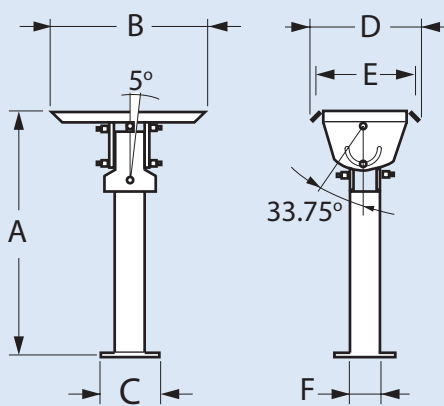

Model Number	Dimensions, mm						App Wt. kg
	A	B	C	D	E	F	
HUNTER-RDR2	600	360	130	245	200	60	20
HUNTER-RDR3	900	360	130	245	200	60	22
HUNTER-RDR4	1210	360	130	245	200	60	24

HUNTER TITAN/ECO SERIES ADJUSTABLE DOWNROD



DESCRIPTION

An all-in-one, pre-wired downrod reduces installation time with a quick connect clamping plate.

The Titan/ECO downrod comes in 3 adjustable sizes accommodating a 760mm to 3040mm drop.

FEATURES

- Pre-wired with power and safety cable
- Comes with guide-wires for extra stability
- Integrated motor mounting plate
- Quick connect clamping system that eliminates the need to drill holes in the building's I-beam
- Self-levelling mount bracket that is locked into place once set
- A proprietary extension power-cable can be added if the installed VFD needs to be mounted outside the blade sweep
- Recommended for the Hunter Titan and ECO series of HVLS fans

DIMENSIONS

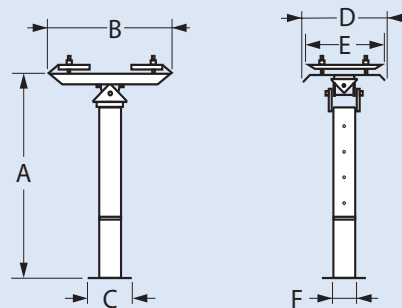

Model Number	Dimensions, mm						App Wt. kg
	A*	B	C	D	E	F	
HUNTER-ADJ-DR34	760						
	910	360	180	245	200	60	19
	1210						
HUNTER-ADJ-DR56	1370						
	1520	360	180	245	200	60	24
	1820						
HUNTER-ADJ-DR710	1980						
	2130						
	2430	360	180	245	200	60	27
	2740						
	3040						

* Dimension A –Incremental height adjustments of the three (3) models